

CUT & SPEC SHEET

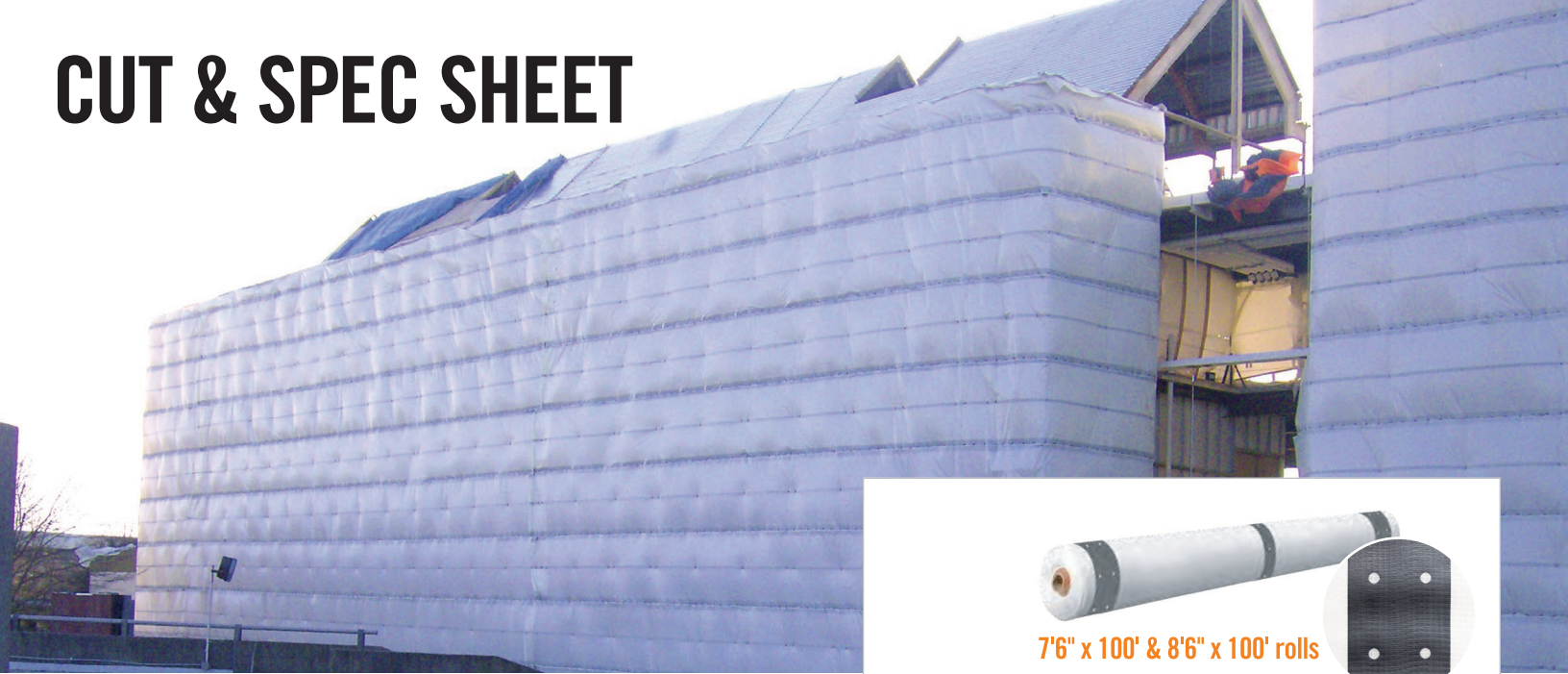

D12/Strong Wrap Fire-Retardant Scaffold Wrap

Strong Man's D12/Strong Wrap is a heavy duty, multiple purpose polyethylene enclosure created to provide super strong jobsite protection. Our durable scaffold wrap is designed with reinforced bands with pre-punched eyelets to make installation faster and easier. When installed with our BC-111 bungee cords, D12/Strong Wrap will create a weather enclosure that allows your project to move forward, regardless of the elements.

USE WITH OUR BC-111 BUNGEE CORDS & HD POLY TAPE TO ENSURE PROPER INSTALLATION!

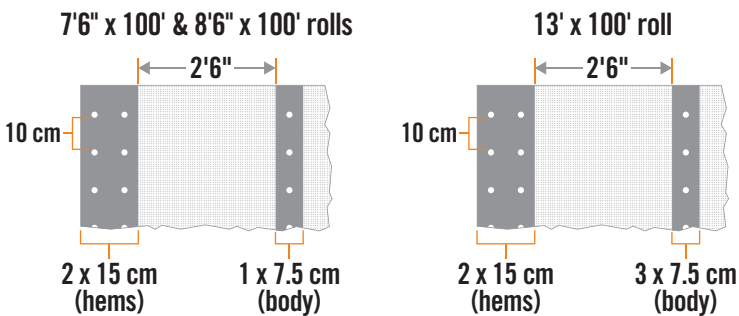

FEATURES

- ▶ Fire-Retardant: Meets NFPA 701 Method II & BFD 1X-1
- ▶ Scrim Reinforced LD Polyethylene
- ▶ Base Material: 3x3 Weave Per Sq. Inch 2400 Denier 250 Grams Per Sq. Meter Milky White Color
- ▶ Reinforced Bands: 14x14 Weave Per Sq. Inch 1200 Denier 190 Grams Per Sq. Meter Pre-Punched 15mm Eyelets For Easy Installation Grey
- ▶ UV Treated & Long Lasting
- ▶ Superior Strength

USES

- ▶ Scaffold Enclosure
- ▶ Debris Protection
- ▶ Sandblast & Dust Containment
- ▶ Paint Overspray
- ▶ Ideal For Use On Scaffold, Bridges, Towers & Tall Buildings

** Specifications subject to change.*



SAFETY ■ SERVICE ■ SOLUTIONS

www.strongman.com

(800) 950-6999



STRONG MAN™ SAFETY PRODUCTS CORP.
Corporate Headquarters and Distribution Center:
240 West Parkway Pompton Plains, NJ 07444
973-831-1555 * 973-831-1525 FAX * 800-950-6999
www.strongman.com

Distribution Centers:

- * Houston, TX
- * Miami, FL
- * Chicago, IL
- * Los Angeles, CA
- * Kent, WA

MEMBER ACIDI, SAIA, STAFDA

© 2019 Strong Man Safety Products Corp.

CUT & SPEC SHEET

SPECIFICATIONS

MATERIAL COMPOSITION	High-strength polyethylene scrim yarns encased with premium poly film		
NOMINAL WEIGHT	7.4 oz./sq. yd		ASTM D-4321
NOMINAL THICKNESS	FABRIC	28 mil	ASTM D-2103
	EYELET BAND	35 mil	
U.V. RESISTANCE	5% U.V. Treatment		
MULLEN BURST STRENGTH	209.08		ASTM D-751
HYDROSTATIC RESISTANCE	132 PSI, Avg		ASTM D-751-06 (2011)
TEAR STRENGTH	LENGTH	47.36 LBF	ASTM D-4533
	WIDTH	33.12 LBF	
TENSILE STRENGTH	LENGTH	77.10 LBF	ASTM D-751
	WIDTH	62.40 LBF	
ELONGATION	LENGTH	17.70%	ASTM D-751
	WIDTH	12.00%	

12" BUNGEE CORDS

BUNGEE CONSTRUCTION	Rubber yarns encased by an elastic material	
TENSILE STRENGTH	Hook: 74 LBF Avg	ASTM D-5034
TENSILE STRENGTH	Toggle: 92 LBF Avg	ASTM D-5034

LOW TEMP: LOW TEMPERATURE CRACK RESISTANCE

ASTM D 751 (-40° F)

SPEC #	RESULTS	
1	Pass	No Cracking
2	Pass	No Cracking
3	Pass	No Cracking

*This data is provided for the benefit of a qualified professional engineer. Above results are based on standard of each individual test. Due to manufacturing allowances, slight variations may appear. To the best of our knowledge, these are typical property values & are intended as guides only, not as specification limits. Strong Man Safety Products makes no warranties as to the fitness for a specific use or merchantability of products referred to, no guarantee of satisfactory results from reliance upon contained information or recommendations, & disclaims all liability for resulting loss or damage.

Sept/2017

D12/Strong Wrap Accessories

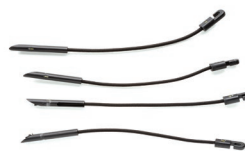

BC-111 Round Barrel Heavy Duty Bungee Cords



Heavy Duty Polyethylene Tape



SAFETY ■ SERVICE ■ SOLUTIONS

www.strongman.com

(800) 950-6999



STRONG MAN™ SAFETY PRODUCTS CORP.
Corporate Headquarters and Distribution Center:
240 West Parkway Pompton Plains, NJ 07444
973-831-1555 * 973-831-1525 FAX * 800-950-6999
www.strongman.com

Distribution Centers:

- * Houston, TX
- * Miami, FL
- * Chicago, IL
- * Los Angeles, CA
- * Kent, WA

MEMBER ACDI, SAIA, STAFDA

© 2019 Strong Man Safety Products Corp.